

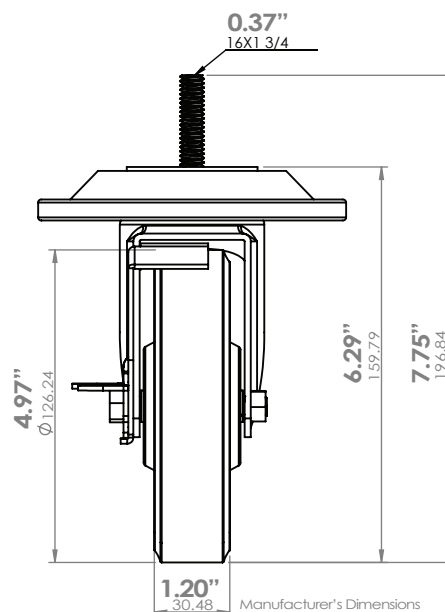

5" HEAVY-DUTY POLYURETHANE THREADED CASTERS [FTCAST5]

- **Design:** 5" (12.7 cm) diameter, 1 1/4" (3.2 cm) face, heavy-duty non-marking polyurethane wheel casters turn your shelving unit into a mobile solution. Each caster includes a 5" (12.7 cm) revolving donut bumper.
- **Load Rating:** Each caster has a load rating of 250 lbs. (113 kg).
- **Special Post Requirements:** These casters are manufactured to be used with posts with feet (i.e. FG033C).

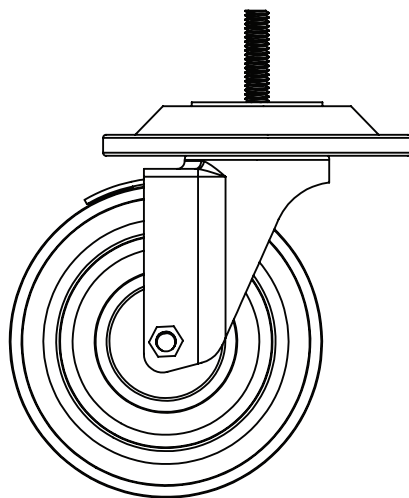
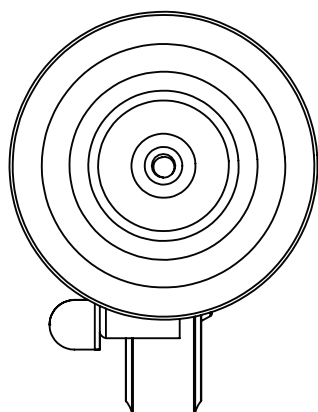

Item #	Description	Pack
FTCAST5*	Set of 4 each 5" (12.7 cm) stem casters (2 swivel & 2 swivel/brake) w/bumpers	4 sets
FTCAST5B	Individual 5" (12.7 cm) swivel stem caster with brake & bumper	4
FTCAST5C	Individual 5" (12.7 cm) swivel stem caster & bumper	4

* Shipped in full color trilingual merchandising carton.

5" HEAVY-DUTY POLYURETHANE THREADED CASTERS