

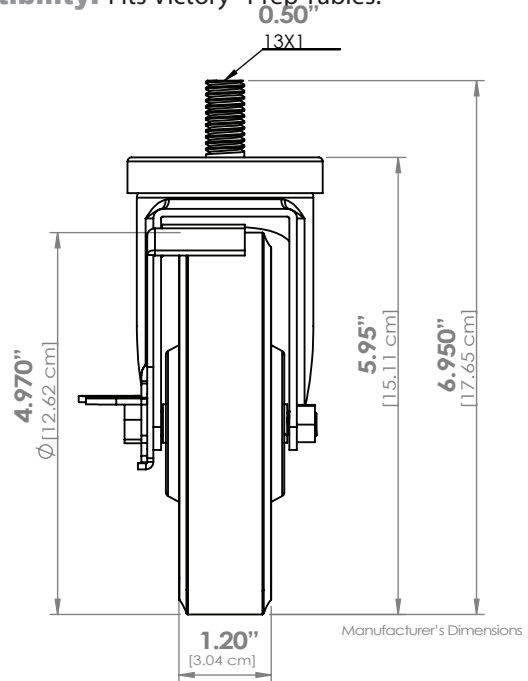

## 5" UNIVERSAL H-D POLYURETHANE THREADED CASTERS FOR EQUIPMENT [FTC121351]

- **Design:** 5" (12.7 cm) diameter, 1 1/4" (3.2 cm) face, heavy-duty grease-resistant, non-marking polyurethane wheel casters fit most foodservice equipment. Adds 6" (15.2 cm) to total height of equipment. Set of 4 includes (2) casters with swivel and (2) casters with swivel and brake.
- **Load Rating:** Each caster has a load rating of 250 lbs. (113 kg).
- **Notable Compatibility:** Fits Victory® Prep Tables.\*\*

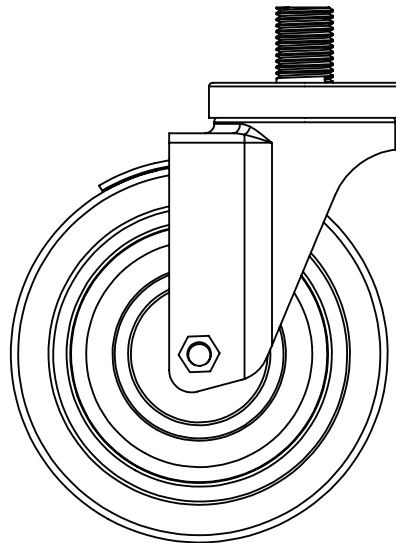
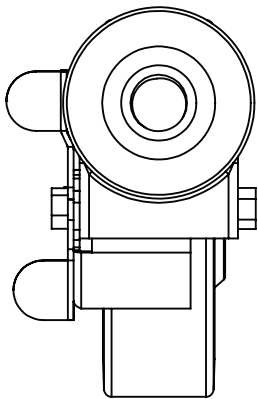

Item #	Description	Pack
FTC121351*	Set of 4 each 5" (12.7 cm) universal threaded casters (2 swivel & 2 swivel with brakes)	4 sets
FT121351E	5" (12.7 cm) universal threaded caster swivel with brake	4

\* shipped in full color trilingual merchandising carton

\*\* This product is not manufactured or authorized by any other manufacturer. Registered Trade Name or Mark of the original manufacturer of the product which this part fits is not owned, associated or to be confused with our company.